

## Product Bulletin



JDS Uniphase supplies unique, diode-pumped, passively Q-switched solid state lasers that are ideal for many OEM applications. These devices produce high intensity, linearly polarized light with superb beam quality in wavelengths ranging from the infrared to the ultraviolet. The new DualChip NanoLaser technology delivers high repetition rate, high peak power light through a unique oscillator amplifier configuration.

The JDS Uniphase DualChip NanoLaser is an entirely passive laser system designed for short pulse generation and amplification. The DualChip incorporates the innovative passively Q-switched NanoLaser cavity consisting of a thin layer of Cr<sup>4+</sup> doped YAG saturable absorber embedded monolithically in the Nd:YAG laser gain medium with two mirrors deposited at the ends. When pumped with a continuous wave diode laser, this cavity emits a high repetition rate, high peak power beam, without the costly and complicated use of electronics required for traditional Q-switched lasers. This beam passes twice, without any electronic synchronization, through a compact, diode pumped, Nd:YVO<sub>4</sub> amplifier selected for its high gain and ability to sustain high repetition rate. The output of the amplifier is a high repetition rate (typically 40 kHz) train of sub-nanosecond pulses with tens of kWatts of peak power.

Ruggedly designed for OEM applications, the DualChip NanoLaser features a hermetically sealed laser head that protects optical compo-

### DualChip NanoLaser Diode pumped high average UV power microchip laser

nents from dust, fumes, condensation, shock and vibration. Its inherent stability avoids the need for costly, complex electronic feedback loops. An optimal thermal environment, maintained by integral air-cooled heat sink, allows the laser to work either as a system component or as a standalone unit. A new OEM controller with voltage autosensing requires no external adjustment, allowing stable laser operation.

#### Key features

- Compact, rugged and simple design
- Passive Q-switching provides improved reliability
- Hermetically-sealed laser head
- Superb beam quality
- High average power
- IR, green and UV models available
- Air cooled built-in heat sink
- Easy computer interface
- Voltage autosensing power supply

#### Applications

- Rapid prototyping, photopolymerization
- Semiconductor manufacturing
- Micro marking
- Writing fiber Bragg gratings
- Material processing
- Trimming array waveguides
- Photoablation
- Laser induced fluorescence

Minimum performance specifications

Models	DNP- 050010-000	DNG- 010010-000	DNV- 005010-000	DNU- 003010-000
Wavelength	1064 nm	532 nm	355 nm	266 nm
Energy /pulse	12.5 μJ	2.5 μJ	1.25 μJ	0.8 μJ
Average power (@40 kHz)	500 mW	100 mW	50 mW	30 mW
Pulse width	< 500 ps	< 500 ps	< 500 ps	< 500 ps
Repetition rate	40 - 50 kHz	40 - 50 kHz	40 - 50 kHz	40 - 50 kHz
Beam profile	TEM <sub>00</sub>	TEM <sub>00</sub>	Near Gaussian	Near Gaussian
Polarization ratio	> 100:1	> 100:1	> 100:1	> 100:1
Beam diameter	1.4 mm	0.8 mm	0.7 mm	0.7 mm
Beam divergence (full angle)	< 1.5 mrad	< 1.5 mrad	< 2 mrad	< 2 mrad
Power stability (1 hour)	± 3 %	± 5 %	± 5 %	± 5 %
Heatsink operating temperature	15 °C - 35 °C	15 °C - 35 °C	15 °C - 35 °C	15 °C - 35 °C
Storage temperature without humidity	10 °C - 50 °C	10 °C - 50 °C	10 °C - 50 °C	10 °C - 50 °C

Compliance to Regulatory Agencies

OEM versions of JDS Uniphase solid state lasers are offered as products for incorporation into other equipment. As such, they have not been certified by CDRH and are to be used only as components. The customer is responsible for CDRH certification of the systems incorporating these products. Please contact JDS Uniphase for information about CDRH compliant models.

Warranty

JDS Uniphase DualChip lasers are warranted to be free of defects in materials and workmanship for six months from the date of shipment.

Licensing Information

This product is sold pursuant to a limited sublicense under certain technology owned by ATX Telecom Systems, Inc. The rights that customers of JDS Uniphase receive through purchase of this product are restricted and exclude any right to use the product in the telecommunications field.

Patent Information

5,495,494 Self-aligned, monolithic, solid microlaser with passive switching by a saturable absorber and production process.

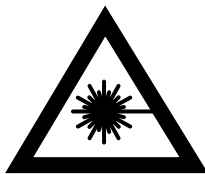

US-CDRH

DualChip NanoLaser Head

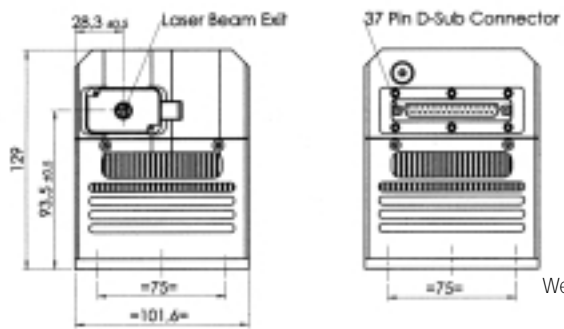
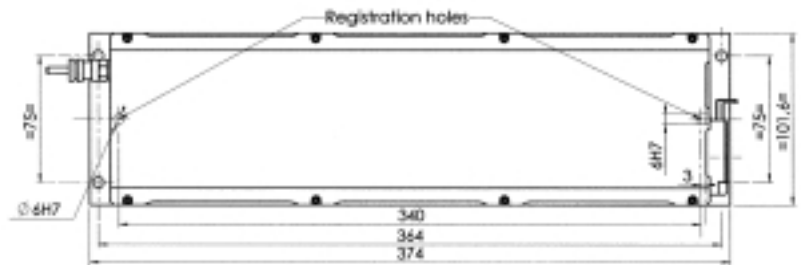

Weight 4.5 Kg

DualChip NanoLaser Power Supply

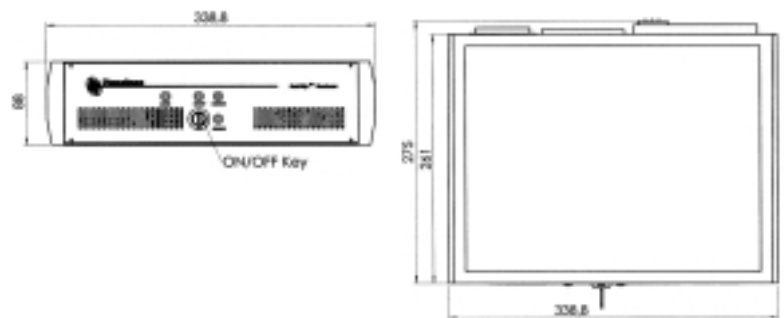

Weight 4.5 Kg



JDS Uniphase Corporation  
163 Baypointe Parkway  
San Jose, California  
95134 USA

Photonic Solutions PLC  
40 Captains Road Edinburgh EH17 8OF  
t:0131 664 8122 f:0131 664 8144  
[www.pspplc.com](http://www.pspplc.com) [sales@psplc.com](mailto:sales@psplc.com)

All information contained herein is believed to be accurate and is subject to change without notice. No responsibility is assumed for its use. JDS Uniphase Corporation, its subsidiaries and affiliates, or manufacturer, reserve the right to make changes, without notice, to product design, product components, and product manufacturing methods. Some specific combinations of options may not be available. Please contact JDS Uniphase for more information. ©JDS Uniphase Corporation. All rights reserved.  
10075064 Rev. A 01/01 Printed in USA